



movimento
materiali
material
handling



giardinaggio
garden



pulizia
industriale
industrial
cleaning



sedile in PU integrale con
inserto metallico interno
*One piece seat in Integral
PU with internal metal frame*

braccioli
armrests
PAG.67

cinture di sicurezza
safety belts
PAG.66

MOL150



MOL220



sospensioni
suspensions
PAG.62

MOL250



MOL550



MOL550SA



MOL698



MOL700



**Configurazione standard /
Standard features:**

Sedile in PU integrale con inserto metallico
interno
*One piece seat in Integral PU with internal
metal frame*

+ Optionals / Options:

Braccioli 2 posizioni
Tilt-up armrests

Cinture di sicurezza 2 punti fisse
Static safety belts

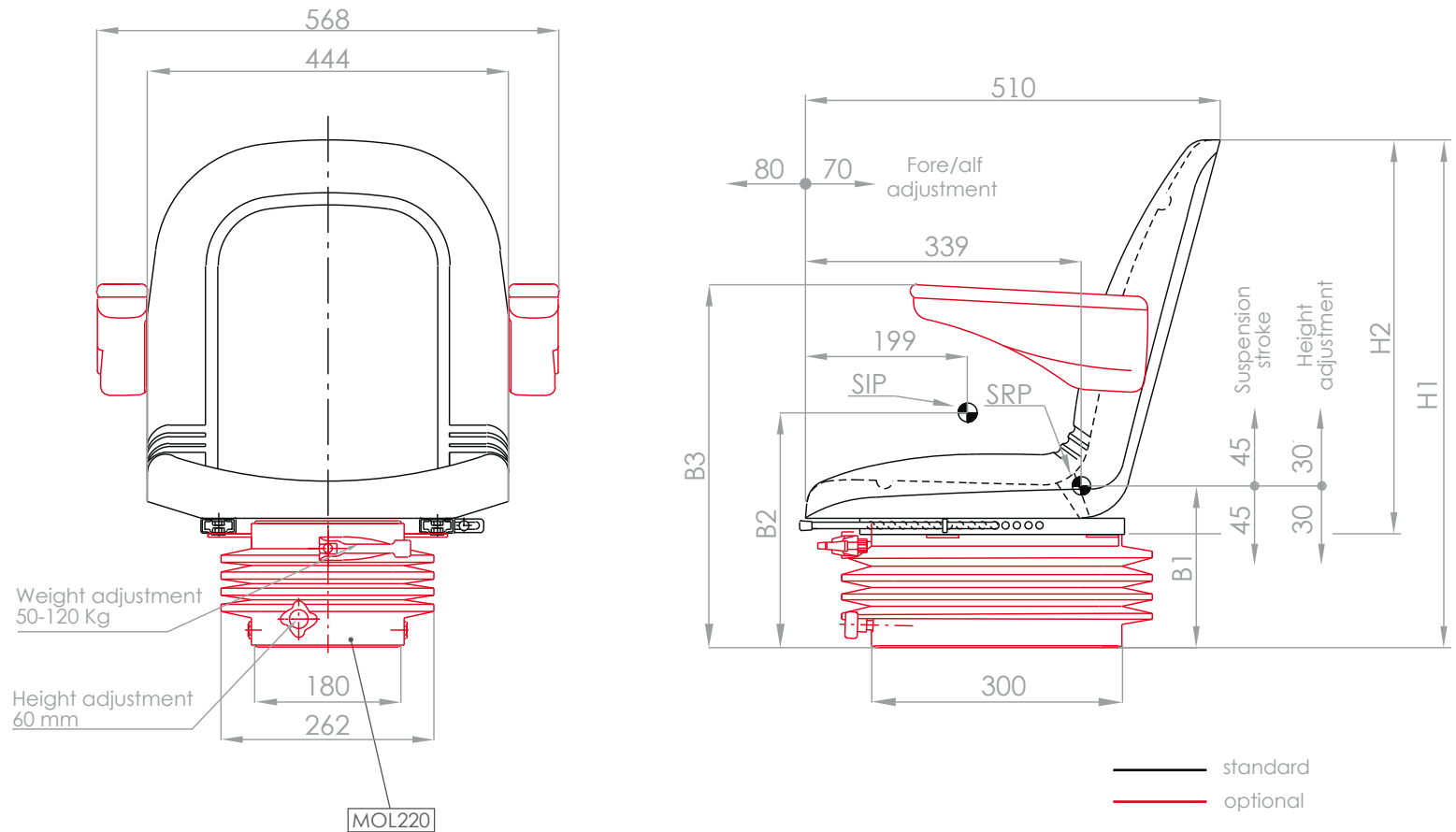

MOL220

↔ Regolazioni / Settings:	
Regolazione continua del peso conducente Continuous adjustment of driver's weight	50 - 120 Kg
Regolazione longitudinale Fore and aft adjustment	150 mm
Regolazione continua altezza sospensione Continuous height adjustment	60 mm

➔ Sospensioni abbinabili - Available suspensions								
		MOL150	MOL220	MOL250	MOL550	MOL550SA	MOL698	MOL700
Dimensioni Dimensions (pag.62)	H1	650	625	635	635	635	630	552
	H2	510	485	495	495	495	490	412
	B1	224	199	209	209	209	204	126
	B2	314	289	299	299	299	294	216
	B3	472	447	457	457	457	452	374
Omologazioni Homologations	CEE 78-764 CEE 83-190 CEE 88-465							
	ISO7096							