

Weight adjustment
50-130 kg

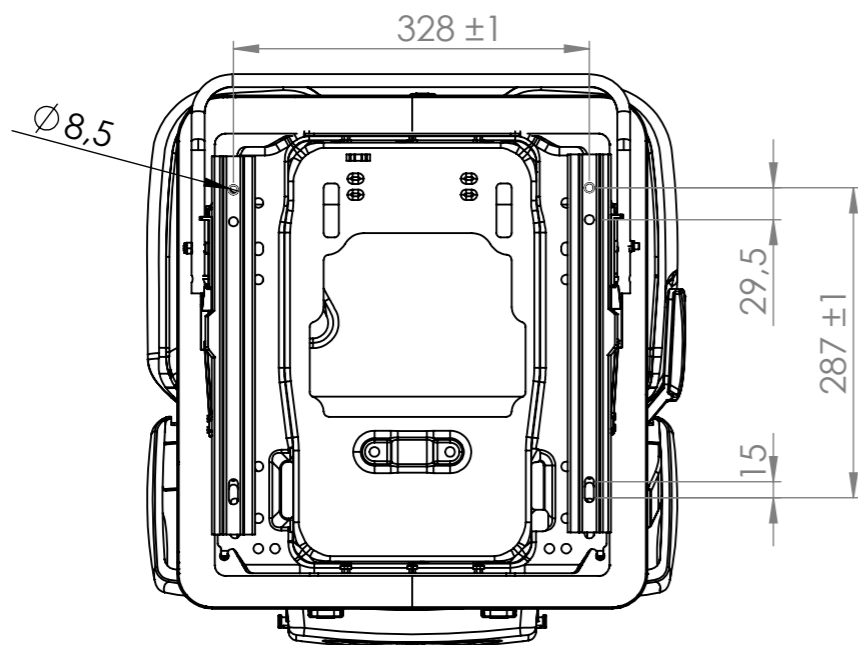

Document holder

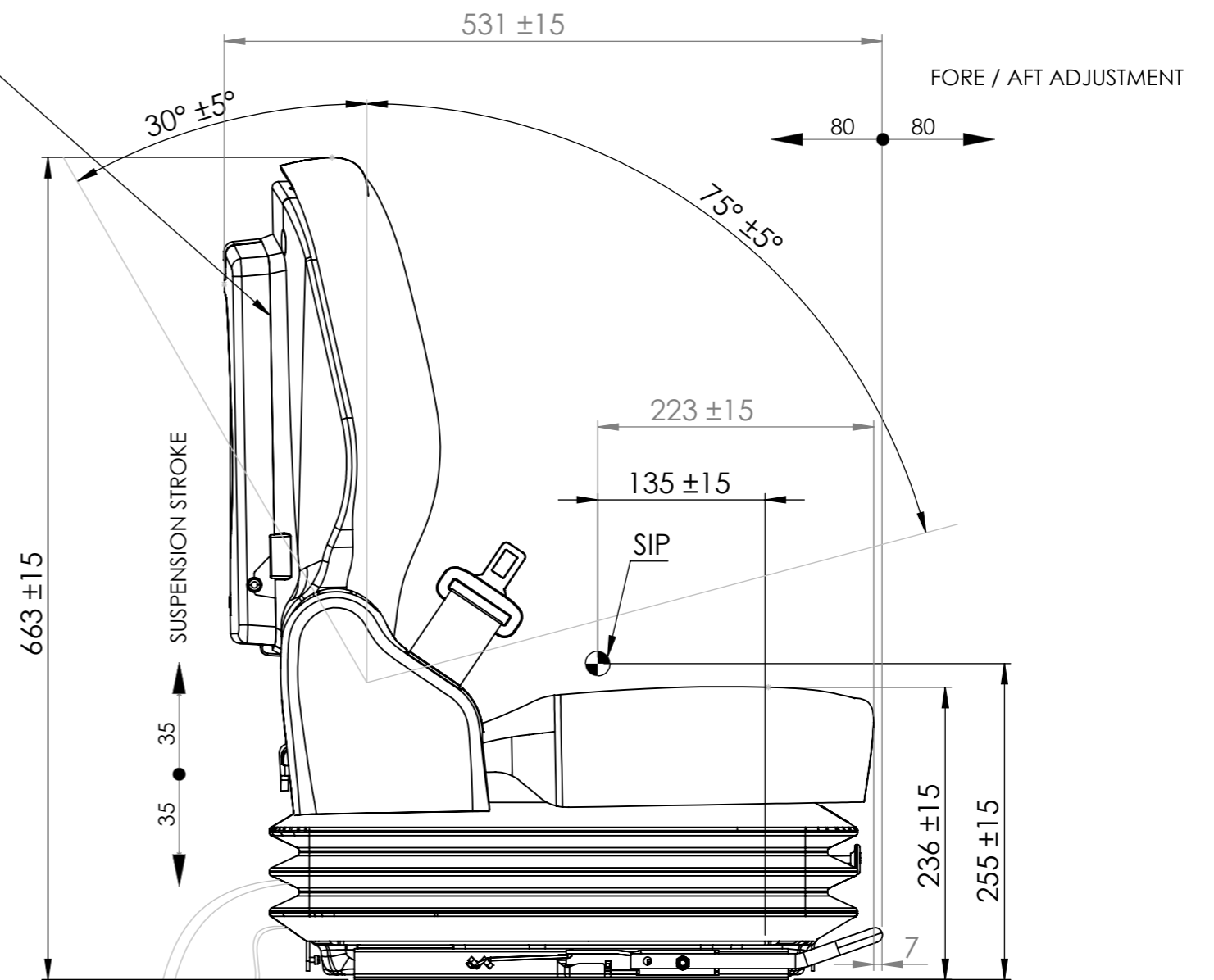

Microswitch cable with connector DT04-6P

PRE-TRATTAMENTO SUPERF. (1st SURF. TREATMENT)		TRATTAMENTO SUPERF. FINALE (LAST SURF. TREAT.)		QUANTITA' (Q.TY)	RUGOSITA' SUPERF. (SURF. ROUGHN.)
TRATT. TERMICO (HEAT TREATMENT)		PESO GREZZO (RAW W.) (Kg.)	PESO FINITO (FINAL W.) (Kg)	FOGLIO (SHEET)	<input checked="" type="checkbox"/> [1.6] <input checked="" type="checkbox"/> [3.2] <input checked="" type="checkbox"/> [6.3]
TOLLERANZE GENERALI CARP. (GENERIC CARPENTRY TOLERANCES) :				SMUSSI NON QUOT : 1X45° - RAGGI : R0,5 (CHAMFERS WITHOUT TOL : 1 X 45° - FILLETS : R0,5)	
CESOIA (SHEARING), PIEGA (BENDING) E OSSITAGLIO (OXYCUTTING) : ± 1 mm - SALDATURA (WELDING) : ± 2 mm - PIEGATURA (BENDING) : ± 1°					
DIM LINE ANG (LIN. & ANG. DIM.)	F	FINE	H	GRADO DI PREC. PER QUOTE LINEARI E ANGOLARI SENZA TOLLERANZA SECONDO UNI-EN 22768-1 (PREC. LEVEL FOR LINEAR AND ANGULAR DIMENSIONS WITHOUT TOL. ACCORDING UNI-EN 22768-1)	
	M	MEDIA (MEDIUM)	K		
	C	GROSSOLANA (COARSE)	L	GRADO DI PREC. PER TOLLERANZE GEOMETRICHE GENERALI SECONDO UNI-EN 22768-2 (PREC. LEVEL FOR GENERIC GEOMETRIC TOL. ACCORDING UNI-EN 22768-2)	
	V	MOLTO GROSSOLANA (VERY COARSE)	-		
DISEGNATO (DRAWN) : Malaguti			MATERIALE (MATERIAL) :		
CONTROLATO (CHKD) : Malaguti			DESCRIZIONE (DESCRIPTION) :		
 CAMPAGNOLA (RE) - ITALY			SEAT SI01 + PNEUMATIC SUSPENSION + DOCUMENT HOLDER + MICROSWITCH + SLIDES + AUTOM. SAFETY BELT + BLACK SKY		
			COD. ATRZ. (TOOL REF.) : --		CODICE (REF.) :
DATA (DATE) 10/12/2024		SCALA (SCALE) 1:5		SI01P1102	

A3