

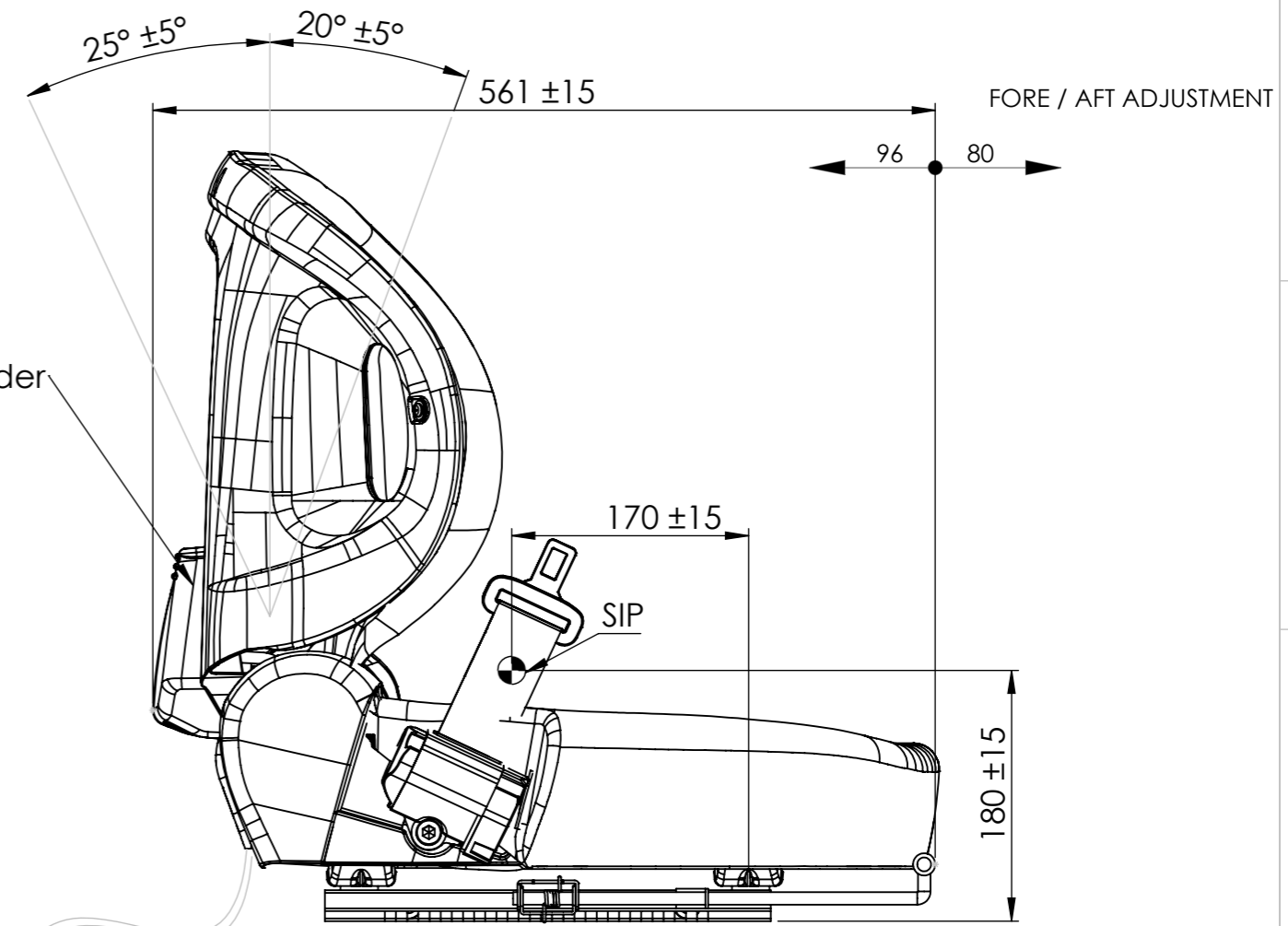

Document holder



Microswitch cable with connector DJ7021-2-11

PRE-TRATTAMENTO SUPERF. (1st SURF. TREATMENT)	TRATTAMENTO SUPERF. FINALE (LAST SURF. TREAT.)	QUANTITA' (Q.TY)	RUGOSITA' SUPERF. (SURF. ROUGHN.)
TRATT. TERMICO (HEAT TREATMENT)	PESO GREZZO (RAW W.) (Kg)	PESO FINITO (FINAL W.) (Kg)	FOGLIO (SHEET)
TOLLERANZE GENERALI CARP. (GENERIC CARPENTRY TOLERANCES) :		SMUSSI NON QUOT : 1X45° - RAGGI : R0,5 (CHAMFERS WITHOUT TOL : 1 X 45° - FILLETS : R0,5)	
CESOIA (SHEARING), PIEGA (BENDING) E OSSITAGLIO (OXYCUTTING) : ± 1 mm - SALDATURA (WELDING) : ± 2 mm - PIEGATURA (BENDING) : ± 1°			
DIM LINE ANG (LIN. & ANG. DIM.)	F FINE	H	TOLL. GEOM. (GEOM. TOLS.)
M	MEDIA (MEDIUM)	K	GRADO DI PREC. PER QUOTE LINEARI E ANGOLARI SENZA TOLLERANZA SECONDO UNI-EN 22768-1 (PREC. LEVEL FOR LINEAR AND ANGULAR DIMENSIONS WITHOUT TOL. ACCORDING UNI-EN 22768-1)
C	GROSSOLANA (COARSE)	L	GRADO DI PREC. PER TOLLERANZE GEOMETRICHE GENERALI SECONDO UNI-EN 22768-2 (PREC. LEVEL FOR GENERIC GEOMETRIC TOL. ACCORDING UNI-EN 22768-2)
V	MOLTO GROSSOLANA (VERY COARSE)	-	
DISEGNATO (DRAWN) : Malaguti		MATERIALE (MATERIAL) :	
CONTROLATO (CHKD) : Malaguti		DESCRIZIONE (DESCRIPTION) :	
		SEAT YY51 + SAFETY BELT + SLIDES + DOCUMENT HOLDER + MICROSWITCH + BLACK SKY	
CAMPAGNOLA (RE) - ITALY		COD. ATRZ. (TOOL REF.) : --	
DATA (DATE) : 07/01/2025		SCALA (SCALE) : 1:5	
		CODICE (REF.) : YY511102	

A3